

Ø21  
柱型孔Ø32x57.5L  
C1.5

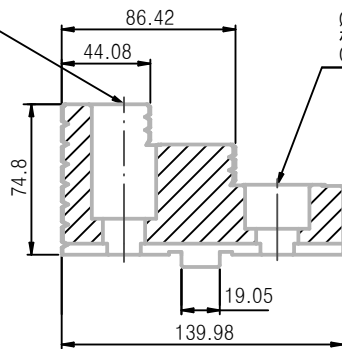

Ø21  
柱型孔Ø32x22.5L  
C1.5

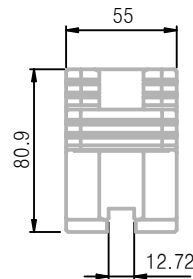

一般公差				機種	FT-A11-20HJ
尺寸範圍	許容差				
1-4	±0.05	單位	MM	件名	上爪
4-16	±0.07				
16-63	±0.1	材質			
63-250	±0.2				
250-1000	±0.3	投影		加工	
1000-1500	±0.5				
比例					